

Self-Tuning Control for Rotation Type Inverted Pendulum Using Two Kinds of Adaptive Controllers

Koji HAGA **, Phornsuk RATIROCH-ANANT *, Hiroshi HIRATA **
Masatoshi ANABUKI ** and Shigeto OUCHI **

* Faculty of Engineering, King Mongkut's Institute of Technology, Ladkrabang, THAILAND

E-mail: ktporns@kmitl.ac.th

** School of Information Technology and Electronics, Tokai University, JAPAN

E-mail: hirata@keyaki.cc.u-tokai.ac.jp

Abstract: *This paper presents the self-tuning control method for the rotation type inverted pendulum that the momentum of inertia of the pendulum part changes widely. The control system prepares two kinds of adaptive controllers, and the stabilization of inverted pendulum is achieved by separating the control mode to two stages. The rotational angle of the pendulum is stabilized by VSS (Variable Structure System) adaptive control method to unknown parameter system at the first stage, and whole basic parameters are simultaneously estimated in the parameter estimation system. After the eigenvalue of the inverted pendulum system converge sufficiently, the controller is changed to LQ (Linear Quadratic) control at the second stage. It is verified by the practical experiment that the proposed self-tuning strategy is very useful as one of the on-line tuning method.*

Key words: inverted pendulum self-tuning control
VSS adaptive control recursive estimation eigenvalue

1. Introduction

So many papers with respect to the stabilization of the inverted pendulum are reported, because it is typically unstable system and is well used as example to verify many control theories. However, few approaches consider the inverted pendulum as unknown parameter system. Slotine and Li [1] proposed adaptive sliding controller that satisfies the desirable properties to nonlinear system having unknown parameters, and proved the validity of the innovative method to the robot manipulator control. Furthermore, T.-P. Leung, et al. [2] proposed AVSMFC (Adaptive Variable Structure Model Following Control) to nonlinear robot system with unknown parameter. Yamakita and Furuta [3] proposed a VSS adaptive control method for the inverted pendulum of rotation type, and verified the effectiveness of the nonlinear control scheme through simulation and experiment. They assume that the pendulum is simple rod for the stabilization of the rotating arm. However, there is difficult problem in applying the adaptive sliding control to the inverted pendulum, since the input number is less than the output number.

This study considers the controlled object [4] of such parameter change that the pendulum expands and contracts under the stabilization. Furthermore, the on-line estimation for a few information systems of the input and output is the

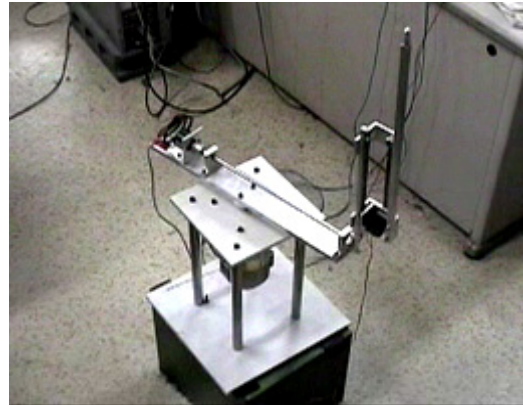

Figure 1 Rotation type inverted pendulum system.

difficult problem and important theme in the auto-tuning. This paper presents the self-tuning control method [5][6] for the rotation type inverted pendulum that the momentum of inertia of the pendulum part changes widely [4]. The control system prepares two kinds of adaptive controllers, and the stabilization of inverted pendulum is achieved by separating the control mode to two stages, which are unknown transient stage and known stable stage. The rotational angle of the pendulum is stabilized by VSS adaptive control method to unknown parameter system at the first stage, and whole basic parameters are simultaneously estimated in the parameter estimation system.

When the designed controller stabilizes the pendulum's angle, the controlled system has little information for the estimation of the system parameter. Whole basic parameters of the stabilized system are estimated by RLS (Recursive Least Square) method under the condition that the available disturbance torque [4] is appended to the control signal on limited short interval. Furthermore, the validity of the convergence decision concerning the estimated parameter is verified by calculating the eigenvalue [7][8] of the inverted pendulum system. After the eigenvalue of the inverted pendulum system converge sufficiently, the controller is changed to LQ control at the second stage.

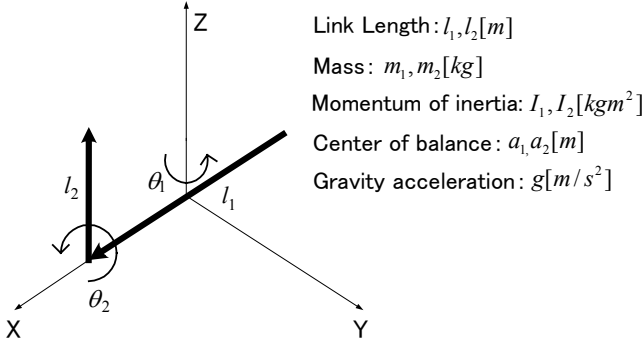

Figure 2 Schematic drawing of inverted pendulum.

2. Dynamics of rotation type inverted pendulum

The inverted pendulum system used in the experiment and its schematic drawings are shown in Figure 1 and Figure 2, respectively. The rotational arm is directly driven by D.C. motor (100V-250W) and also the link of pendulum is driven to straight by rack and pinion gear connected to small D.C. motor (24V-6.4W). Dynamic equation of such rotation type inverted pendulum can be written in the following general form

$$\tau = M(\theta)\ddot{\theta} + C(\theta, \dot{\theta})\dot{\theta} + G(\theta) + B\dot{\theta} + D(\dot{\theta}), \quad (1)$$

where τ is the motor torques, and θ , $\dot{\theta}$ and $\ddot{\theta}$ are the joint angles, velocities and accelerations, respectively. $M(\theta)$ is the inertia matrix, $C(\theta, \dot{\theta})\dot{\theta}$ represents the torques arising from centrifugal and Coriolis forces. $B\dot{\theta}$, $D(\dot{\theta})$ and $G(\theta)$ represent the friction torques acting at rotational joints, and the gravitational torques respectively. In the case of neglecting the Coulomb friction of the pendulum part, the terms in (1) can be obtained as follows:

$$M(\theta) = \begin{bmatrix} J_1 + J_2 S_2^2 & -r l C_2 \\ -r l C_2 & J_2 \end{bmatrix}, \quad (2)$$

where $J_1 = I_1 + m_1 a_1^2 + m_2 l^2$, $l = l_1 / 2$, $J_2 = I_2 + m_2 a_2^2$, $r = m_2 a_2$, $S_2 = \sin(\theta_2)$, $C_2 = \cos(\theta_2)$, $\theta = [\theta_1 \ \theta_2]^T$ and

$$C(\theta, \dot{\theta})\dot{\theta} = \begin{bmatrix} 2J_2 S_2 C_2 \dot{\theta}_1 \dot{\theta}_2 + r l S_2 \dot{\theta}_2^2 \\ -J_2 S_2 C_2 \dot{\theta}_1^2 \end{bmatrix}, \quad G(\theta) = \begin{bmatrix} 0 \\ -r g S_2 \end{bmatrix},$$

$$B\dot{\theta} = \begin{bmatrix} b_1 \dot{\theta}_1 \\ b_2 \dot{\theta}_2 \end{bmatrix}, \quad D(\dot{\theta}) = \begin{bmatrix} d_1 \text{sgn}(\dot{\theta}_1) \\ 0 \end{bmatrix}, \quad \tau = [\tau_1 \ 0]^T. \quad (3)$$

3. Design of control system

The control system prepares adaptive controllers of two types. The rotational angle of the pendulum is stabilized by VSS adaptive control method to unknown parameter system at the first stage. After the eigenvalue of the inverted

pendulum system converges sufficiently, the controller is changed to LQ control at the second stage.

3.1 Stabilization of pendulum part

VSS adaptive stabilization system for only rotational angle of the pendulum is designed to the linear approximation system nearby the origin of equation (1) given by

$$\begin{cases} J_1 \ddot{\theta}_1 - r l \ddot{\theta}_2 + b_1 \dot{\theta}_1 + d_1 \text{sgn}(\dot{\theta}_1) = \tau_1 \\ -r l \ddot{\theta}_1 + J_2 \ddot{\theta}_2 - r g \theta_2 + b_2 \dot{\theta}_2 = 0 \end{cases} \quad (4)$$

Using the motor torque constant k_τ and the motor current i , the input torque τ_1 is given by $\tau_1 = k_\tau i$. Equation (4) can be rewritten by

$$(\det M)\ddot{\theta}_2 + J_1 b_2 \ddot{\theta}_2 - J_1 r g \theta_2 + r l b_1 \dot{\theta}_1 + r l d_1 \text{sgn}(\dot{\theta}_1) = r l k_\tau i, \quad (5)$$

where $\det M$ is defined by $\det M = J_1 J_2 - (r l)^2$.

Let the switching function s as

$$s = \dot{\theta}_2 + c \theta_2, \quad (6)$$

then the system (5) is described as follows:

$$Y^T a + H \dot{s} = i + w, \quad (7)$$

where H is $H = (\det M) / r l k_\tau$, w represents the equivalent disturbance term, and two following vector pairs of both Y and a are considered:

$$\begin{cases} Y^T = [\ddot{\theta}_2 - \dot{s} \quad \dot{\theta}_2 \quad \theta_2 \quad \dot{\theta}_1 \quad \text{sgn}(\dot{\theta}_1)] \\ a^T = [H \quad J_1 b_2 / r l k_\tau \quad -J_1 g / l k_\tau \quad b_1 / k_\tau \quad d_1 / k_\tau] \end{cases} \quad (8)$$

$$\begin{cases} Y^T = [\ddot{\theta}_2 - \dot{s} \quad \dot{\theta}_2 \quad \theta_2] \\ a^T = [H \quad J_1 b_2 / r l k_\tau \quad -J_1 g / l k_\tau] \end{cases} \quad (9)$$

Using the estimation \hat{a} , the control input i and the adaptation law are given by

$$i = Y^T \hat{a} - k \text{sgn}(s) \quad (10)$$

$$\dot{\hat{a}} = -\Gamma^{-1} Y s \quad (11)$$

where k is positive scalar value and Γ is constant positive definite matrix.

The control system then guarantees the global stability. The following candidate of Liapunov function is considered to prove this:

$$V(t) = \frac{1}{2} [s H s + \tilde{a}^T \Gamma \tilde{a}]. \quad (12)$$

Differentiating $V(t)$, the following result yields

$$\begin{aligned} \dot{V}(t) &= s H \dot{s} + \tilde{a}^T \Gamma \dot{\tilde{a}} = s(i - Y^T \hat{a} - Y^T \tilde{a} + w) + \tilde{a}^T \Gamma \dot{\tilde{a}} \\ &= s(-k \text{sgn}(s) + w) + \tilde{a}^T \Gamma (\dot{\tilde{a}} - \Gamma^{-1} Y s). \end{aligned} \quad (13)$$

Above second term is removed by the adaptation law. If the gain k is larger than the absolute value of disturbance w , it leads to

$$\dot{V}(t) = -(k |s| - s w) \leq -|s|(k - |w|) \leq 0. \quad (14)$$

Therefore, the conditions of the sliding mode are satisfied and the rotational angle θ_2 of the pendulum converges to zero. Furthermore, using the boundary layer thickness δ , undesirable chattering of the switching control law (10) is appropriately prevented.

3.2 Stabilization of whole parts

The LQ controller of including the estimation system is considered for unknown parameter system. The adaptive law of the previous subsection does not give whole basic parameters for LQ controller design. Hence, the following recursive estimation system is employed for the control purpose.

Linear parameterization

Such linear parameterization as equations (8) and (9) is not sufficient for LQ controller design. Therefore, we use linear parameterized form described by

$$\tau = M(\theta)\ddot{\theta} + C(\theta, \dot{\theta})\dot{\theta} + G(\theta) + B\dot{\theta} + D(\theta) = \Phi^T(\theta, \dot{\theta}, \ddot{\theta})\delta, \quad (15)$$

where the input torque τ is $\tau = [\tau_1 \ 0]^T$ and the regressor $\Phi(\theta, \dot{\theta}, \ddot{\theta})$ and the basic parameter δ are given by

$$\Phi^T(\theta, \dot{\theta}, \ddot{\theta}) := \begin{bmatrix} \ddot{\theta}_1 & \phi_{12} & \phi_{13} & \dot{\theta}_1 & 0 & \text{sgn}(\dot{\theta}_1) \\ 0 & \phi_{22} & \phi_{23} & 0 & \dot{\theta}_2 & 0 \end{bmatrix}, \quad (16)$$

$$\phi_{12} = S_2^2 \ddot{\theta}_1 + 2S_2 C_2 \dot{\theta}_1 \dot{\theta}_2, \quad \phi_{13} = l(S_2 \dot{\theta}_2^2 - C_2 \ddot{\theta}_2),$$

$$\phi_{22} = \ddot{\theta}_2 - S_2 C_2 \dot{\theta}_1^2, \quad \phi_{23} = -lC_2 \ddot{\theta}_1 - gS_2$$

and

$$\delta := [J_1 \ J_2 \ r \ b_1 \ b_2 \ d_1]^T. \quad (17)$$

In the case with uncertainty in the torque constant, Eq.(15) is changed to Eq.(18) because it is useful for the estimation of the basic parameter included the torque constant.

$$i = \Phi^T(\theta, \dot{\theta}, \ddot{\theta})\sigma, \quad \sigma = \delta / k_\tau = [\sigma_1 \ \sigma_2 \ \sigma_3 \ \sigma_4 \ \sigma_5 \ \sigma_6]^T. \quad (18)$$

where the input current i is $i = [i \ 0]^T$.

Acquisition of regressor

Only the motor current and the rotational angles are used as the measurement data of the inverted pendulum, other required motion data like the angular velocities and the angular accelerations are obtained by using the low pass filter including the derivative filter. When the identification system has different sensor dynamics, the estimation accuracy generally deteriorates.

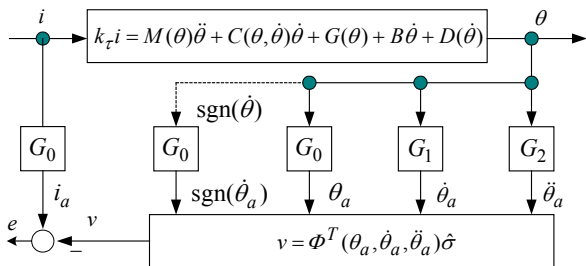

Figure 3 Acquisition of regressor for estimation system.

Hence, the filter structure shown in Figure 3 is introduced to compensate the difference of the sensor characteristics. The necessary motion data $\{\theta_a(k), \dot{\theta}_a(k), \ddot{\theta}_a(k), i_a(k)\}$ for the estimation is obtained by the following various filters [9].

$$\begin{cases} i_a = G_0 i, & \theta_a = G_0 \theta \\ \text{sgn}(\dot{\theta}_a) = G_0 \text{sgn}(\dot{\theta}), & \dot{\theta} \equiv \{\theta(k) - \theta(k-1)\} / T \\ \dot{\theta}_a = G_1 \dot{\theta}, & \ddot{\theta}_a = G_2 \ddot{\theta} \end{cases} \quad (19)$$

$$G_0 = \frac{1}{(1 + \tau_f s)^3}, \quad G_1 = s G_0, \quad G_2 = s^2 G_0 \quad (20)$$

The operation of these filters is also calculated in discrete form using the bilinear transformation:

$$s = \frac{2}{T} \left(\frac{z-1}{z+1} \right), \quad T: \text{sampling period}. \quad (21)$$

Recursive estimation system

The estimate model is defined as

$$v(k) = \Phi^T(k) \hat{\sigma}(k), \quad (22)$$

where $\hat{\sigma}(k)$ and $v(k)$ are, respectively, the estimated basic parameter and the output of the estimate model, $\Phi(k)$ is the regressor of (16).

The recursive estimation is completed in every sampling interval by filling the following motion data

$$\Delta_a := \{\theta_a(k), \dot{\theta}_a(k), \ddot{\theta}_a(k), i_a(k)\}. \quad (23)$$

The parameter adaptation theorem that ensured the asymptotic stability of the parameter convergence is given below by the simplified form. The adaptation algorithm is also equivalent to RLS estimation.

[Adaptation theorem] Let $\eta(k)$ be the parameter error defined by

$$\eta(k) = \sigma - \hat{\sigma}(k). \quad (24)$$

If the estimated parameter $\hat{\sigma}(k)$ is adjusted with

Parameter adjusting:

$$\eta(k) = \eta(k-1) - P(k-1) \Phi(k) e(k), \quad (25)$$

Output error:

$$e(k) = \frac{1}{\lambda(k) + \text{tr}[\Phi^T(k) P(k-1) \Phi(k)]} \varepsilon(k), \quad (26)$$

Prediction error:

$$\varepsilon(k) = i(k) - \Phi^T(k) \hat{\sigma}(k-1), \quad (27)$$

Adaptive gain:

$$P(k) = \frac{1}{\lambda(k)} \left\{ P(k-1) - \frac{P(k-1) \Phi(k) \Phi^T(k) P(k-1)}{\lambda(k) + \text{tr}[\Phi^T(k) P(k-1) \Phi(k)]} \right\} \quad (28)$$

where $0 < P^{-1}(0)$, $0 < \lambda(k) \leq 1$,

then, the convergence of the output error $e(k)$ is ensured as $e(k) \rightarrow 0$, $(k \rightarrow \infty)$.

The weighting sequence $\lambda(k)$ is usually chosen within $0.98 < \lambda(k) \leq 1$ and μ is the constant for adjusting $\lambda(k)$. We use the following sequence

$$\lambda(k) = (1 - \mu)\lambda(k) + \mu. \quad (29)$$

State equation using the basic parameter

The basic parameter is obtained by the estimation of the nonlinear system mentioned above. In order to apply the optimal regulator design, the linear approximation of equation (4) can be rewritten to the state equation form without the disturbance. Define the input, the output and the state variable as $u = i$, $y = [\theta_1 \ \theta_2]^T$ and $x = [\theta_1 \ \dot{\theta}_1 \ \theta_2 \ \dot{\theta}_2]^T$, respectively. Then, the state space expression $\Sigma_s: (A, B, C)$ is described by using the estimated basic parameter $\hat{\sigma}(k)$ as follows:

$$A = \begin{bmatrix} 0 & 1 & 0 & 0 \\ 0 & -\frac{\sigma_2 \sigma_4}{\det} & \frac{lg \sigma_3^2}{\det} & -\frac{l \sigma_3 \sigma_5}{\det} \\ 0 & 0 & 0 & 1 \\ 0 & -\frac{l \sigma_3 \sigma_4}{\det} & \frac{g \sigma_1 \sigma_3}{\det} & -\frac{\sigma_1 \sigma_5}{\det} \end{bmatrix}, \quad B = \begin{bmatrix} 0 \\ \frac{\sigma_2}{\det} \\ 0 \\ \frac{l \sigma_3}{\det} \end{bmatrix} \quad (30)$$

$$C = \begin{bmatrix} 1 & 0 & 0 & 0 \\ 0 & 0 & 1 & 0 \end{bmatrix}, \quad \det = \sigma_1 \sigma_2 - l^2 \sigma_3^2. \quad (31)$$

Self-tuning control system

Figure 4 shows the self-tuning control system of the inverted pendulum. VSS adaptive controller of previous subsection stabilizes the rotational angle of the pendulum at the first stage, and the estimation system simultaneously estimates basic parameters $\hat{\sigma}(k)$ in order to prepare to the second stage. The feedback gain F is designed by the optimal regulator using the system $\Sigma_s: (A, B, C)$ obtained in the estimation part. The eigenvector method based on Hamilton matrix quickly solves Riccati equation of LQ problem. The proposed self-tuning controller effectively stabilizes the inverted pendulum having unknown parameters.

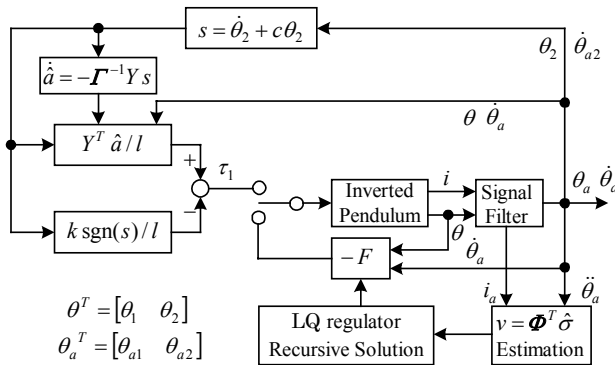

Figure 4 Self-tuning control system for inverted pendulum.

Table1: Basic parameters of inverted pendulum model.

σ_1	σ_2	σ_3	σ_4	σ_5	σ_6
9.779e-2	5.590e-2	0.2692	2.504e-3	7.410e-4	0.1351

Table2: Condition of simulation for VSS controller.

coefficient c in switching function	$c = 10$
scalar gain k in control input	$k = 3.0$
matrix gain $\Gamma = \rho I$ in adaptive law	$\rho = 100$
boundary layer δ in saturation function	$\delta = 0.5$
sampling period T	$T = 0.001$

4. Simulation of VSS controller and estimation system

The validity of the proposed system is verified through the numerical simulation. Only VSS adaptive control is executed to the inverted pendulum having unknown parameters under the condition that the available disturbance torque (the amplitude of 1 volt is bipolar and the period is also 1 second) is appended to the control signal for five seconds from starting. Table1 and Table2 are the basic parameter of nonlinear model and the condition used in the control simulation, respectively.

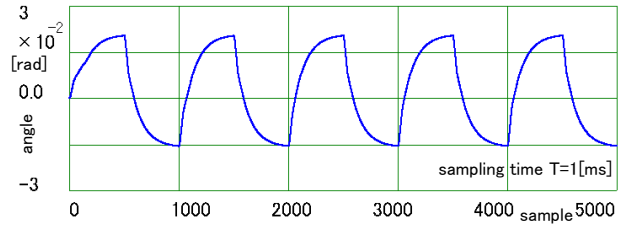

Figure 5 Rotational Angle of inverted pendulum.

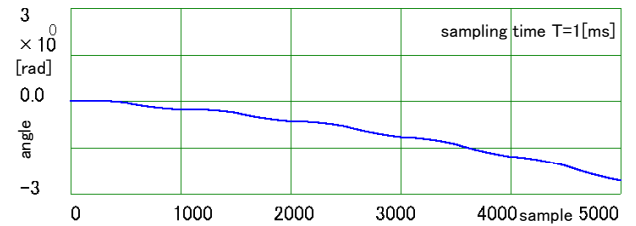

Figure 6 Rotational angle of rotating arm.

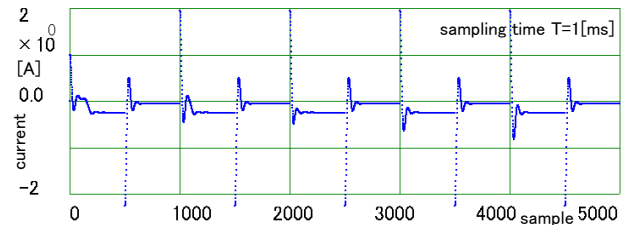

Figure 7 Control input appended the disturbance.

Furthermore, it uses vector pair (9) in the control input (10). Figure 5 and Figure 6 show the rotational angles of the inverted pendulum and the rotating arm, respectively. Figure 7 is the control input that appends the disturbance mentioned above for the improvement of the estimation accuracy. The pendulum never falls down due to the effect of VSS adaptive control, though it slightly sways like the limit cycle by the disturbance torque. Figure 8 shows the estimated basic parameter that is estimated by using nonlinear model (22). Finally, Figure 9 and Figure 10 show, respectively, the eigenvalue calculated by the estimated basic parameter and the feedback gain designed by LQ regulator. They are quickly calculated by means of both algorithms of Householder's method using the elementary Hermitian transformation and QR method using the unitary matrix of Givens. These calculations are repeated in every sampling interval within 1 [msec]. Table3 is also the estimation result that shows a good accuracy based on Figure 8.

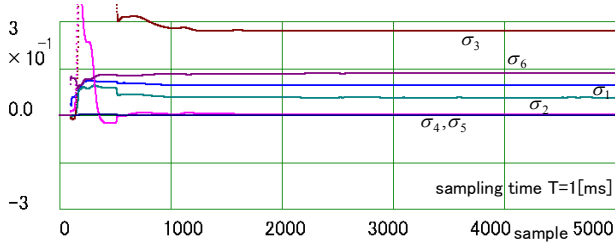

Figure 8 Transition of estimated basic parameter.

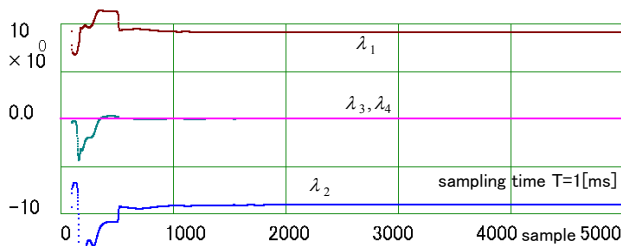

Figure 9 Transition of eigenvalues of inverted pendulum.

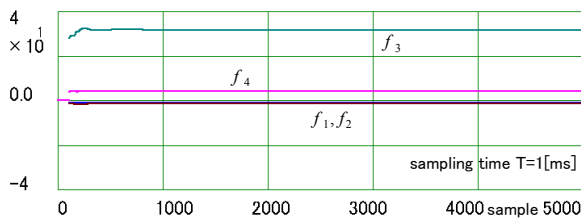

Figure 10 Feedback gain calculated by LQR design.

Table3: Result of recursive estimation.

$\hat{\sigma}_1$	$\hat{\sigma}_2$	$\hat{\sigma}_3$	$\hat{\sigma}_4$	$\hat{\sigma}_5$	$\hat{\sigma}_6$
9.781e-2	5.584e-2	0.2689	1.792e-3	1.120e-3	0.1354

It is obvious that the preparation of shifting the controller is sufficient, though the simulation does not change the controller to LQ controller.

5. Experiment of self-tuning control

The experiment of the proposed strategy is executed by means of same VSS controller condition as previous section. At first, the rotational angle of pendulum is stabilized by VSS adaptive control to unknown parameter system with setting all zeros of adjustable parameter (11). The available disturbance torque for the improvement of the estimation accuracy is appended to the control signal for five seconds from starting same as case of the simulation. When the eigenvalue of the system converges sufficiently, the feedback gain similarly converges. Hence, after passage of 2 seconds from starting, the controller is changed to the adaptive LQ controller. Figure 11 and Figure 12 show the rotational angles of the inverted pendulum and the rotating arm, respectively. Both angles of pendulum and rotating arm are appropriately stabilized by means of the proposed self-tuning strategy. Figure 13 is the control input that is appending the disturbance. Though the controller is changed, the appending of the disturbance is continued until passage of 5 seconds for the confirmation of the adaptive system. Figure 14 shows the estimated basic parameter that is estimated by using nonlinear model (22). The time constant τ_f of the various filter uses $\tau_f = 0.03$ in the acquisition of the regressor matrix $\Phi(k)$. Table4 is one example of the estimation result that shows slow fluctuation based on Figure 14. Using their basic parameters, one optimal feedback gain $F = [-1.000 \ -1.532 \ 29.414 \ 3.566]$ is designed by the following weight in LQ regulator:

$$Q = \text{diag}[1 \ 1 \ 100 \ 1], \quad r = 1.$$

Furthermore, Figure 15 and Figure 16 show the eigenvalue and the feedback gain, respectively. Slow fluctuation of the parameter appears to the estimation of the Figure 14 due to the influence of both noise and uncertainty. However, both eigenvalue and feedback gain rarely fluctuate compared with the parameter transition after passage of 3 seconds.

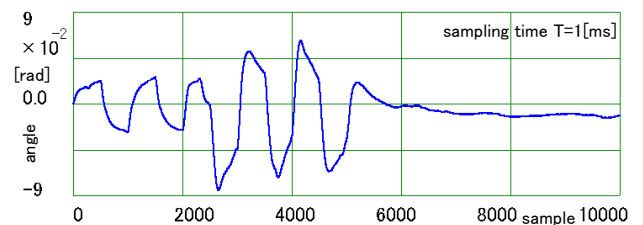

Figure 11 Rotational Angle of inverted pendulum.

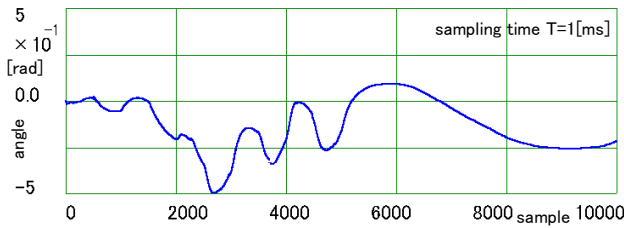

Figure 12 Rotational angle of rotating arm.

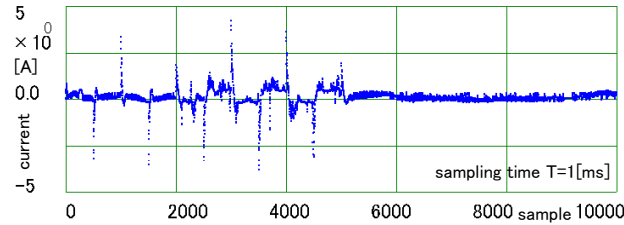

Figure 13 Control input with disturbance for only 5 [sec].

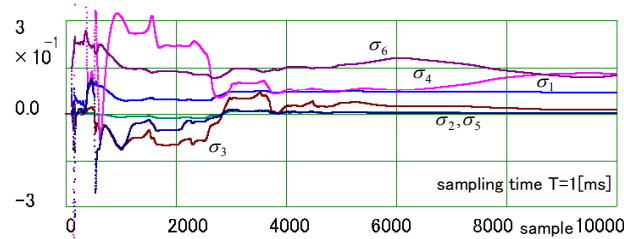

Figure 14 Transition of estimated basic parameter.

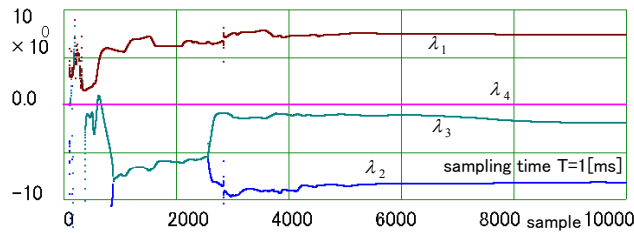

Figure 15 Transition of eigenvalues of inverted pendulum.

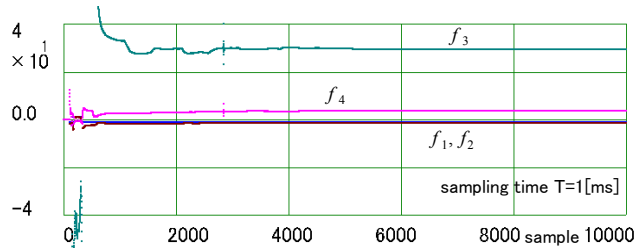

Figure 16 Feedback gain calculated by LQR design.

Table4: Result of recursive estimation.

$\hat{\sigma}_1$	$\hat{\sigma}_2$	$\hat{\sigma}_3$	$\hat{\sigma}_4$	$\hat{\sigma}_5$	$\hat{\sigma}_6$
6.946e-2	2.283e-3	1.356e-2	0.1320	1.770e-3	0.1256

Therefore, we will support through the experiment the conclusion that the eigenvalue of the system is effective in order to judge the convergence of the estimation.

6. Conclusions

This paper presents the self-tuning control method for the rotation type inverted pendulum that changes widely the momentum of inertia of the pendulum. The proposed self-tuning control system prepares two kinds of adaptive controllers, and the stabilization of inverted pendulum is achieved by separating the control mode to two stages of VSS adaptive control and LQ adaptive control. The parameter estimation of the inverted pendulum is effectively executed in the stage of VSS adaptive control and after the eigenvalue of the inverted pendulum system converge sufficiently, the controller is changed to the stage of LQ adaptive control. The validity of the proposed system is demonstrated through some numerical simulations and practical experiments.

References

- [1] J.-J. E. Slotine and W. Li, "Adaptive manipulator control: A Case study", IEEE Trans. AC-33, No.11, 1988, pp.995-1003.
- [2] T.-P. Leung, Q.-J. Zhou, C.-Y. Su, "An Adaptive Variable Structure Model Following Control Design for Robot Manipulators", IEEE Trans. AC-36, No.3, 1991, pp.347-353.
- [3] M. Yamakita, K. Furuta, K. Konohara, J. Hamada & H. Kusano, "VSS Adaptive Control Based on Nonlinear Model for TITech Pendulum", IEEE IECON'92, 1992, pp. 1488-1493.
- [4] R. Phornsuk, M. Anabuki & H. Hirata, "Self-Tuning Control for Rotational Inverted Pendulum by Eigenvalue Approach", IEEE TENCON'04, 2004, Chiang Mai, pp.542-545.
- [5] K. J. Åström & B. Wittenmark, *Adaptive Control*, Addison Wesley, 1989.
- [6] J.-J. E. Slotine and W. Li, *Applied nonlinear control*, Prentice Hall, 1991.
- [7] D.Kincaid & W.Cheney, *Numerical Analysis*, Brooks/Cole, 1991.
- [8] S. NAKAMURA, *Applied Numerical Methods with Software*, Prentice Hall, 1991.
- [9] R.Phornsuk, M.Anabuki & H. Hirata, "Adaptive motion control of a two-link Direct Drive Manipulator using disturbance observer", IEEE TENCON'02, 2002, Beijing, pp.1725-1728.